

12 pin Molex connector on rear of Navaid AP-1. This view is of the connector looking at the back of the AP-1 head, or the wiring side of the mating connector.

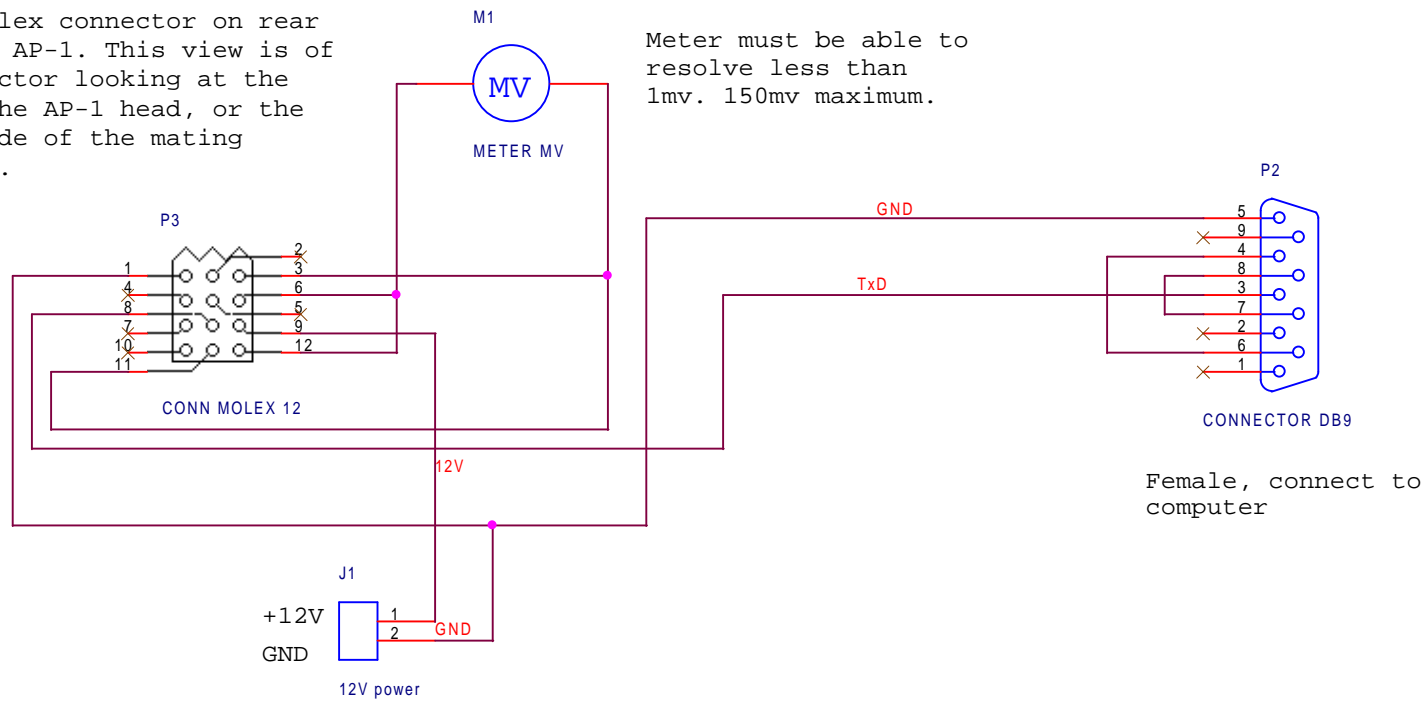

Meter must be able to resolve less than 1mv. 150mv maximum.

Fixture to connect PC-type computer to Navaid AP-1 with built-in Smart Coupler. For use with either DOS or Windows-based test and calibration program.

Porcine Associates
244 O'Connor St.
Menlo Park, CA 94025
(650) 326-2669
www.porcine.com

Fixture for test/calibration of AP-1 with Smart Coupler

Size A	CAGE Code	DWG NO Test and Calibration - AP-1	Rev A
Wednesday, May 15, 2002		Scale	Sheet 1 of 1